

## Without bushing 無軸套

Horizontal

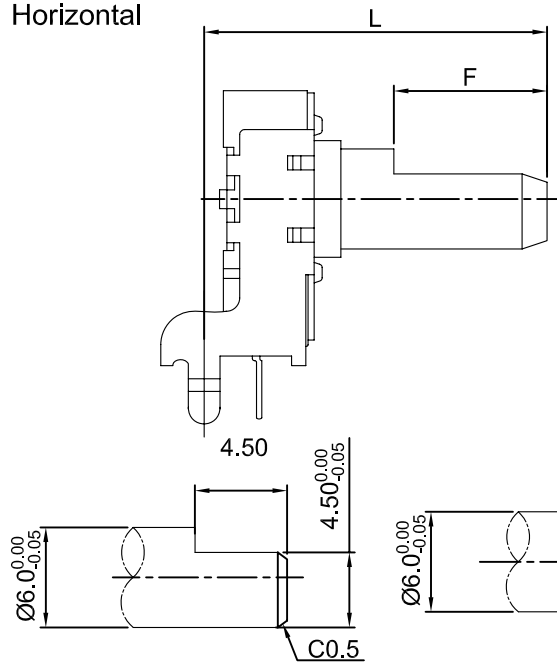

Vertical

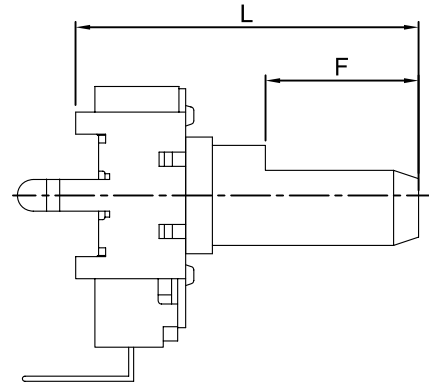

F TYPE:

X	A	B	C	D	E
L	15	20	25	30	35
F	4.5	7	12	12	12

## With bushing 有軸套

Horizontal

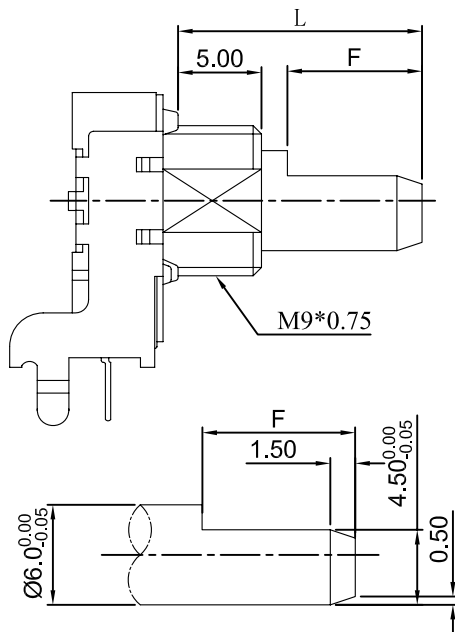

Vertical

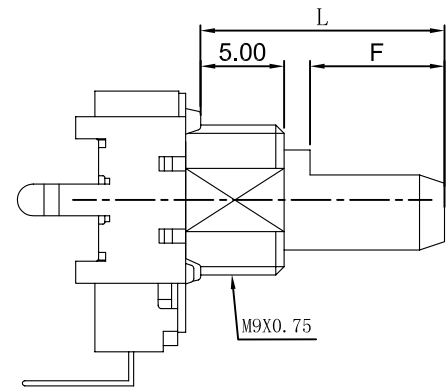

F TYPE:

X	I	G	A	H	B	J	C	K	D
L	7.5	12.5	15	17.5	20	22.5	25	27.5	30
F	2.6	7	7	12	12	12	12	12	12

## Circuit explanation 電路說明

N

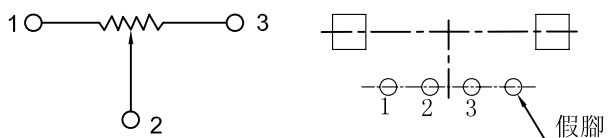

P

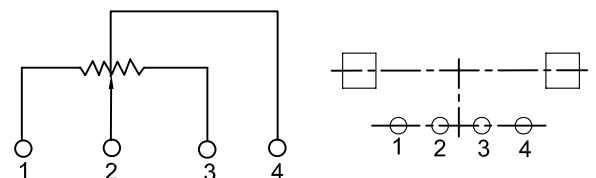

電氣的性能 :Electrical Characteristics

全阻抗值 (Total Resistance)	500Ω~2MΩ
全阻抗值允許偏差 (Total Resistance Tolerance)	±20%(more than 1MΩ±30%)
阻值變化特性 (Resistance Taper)	A、B、C
殘留阻值 (Residual Resistance)	R ≥ 250KΩ 0.1% max.of total resistance 10KΩ < R < 250KΩ 20Ω max. R ≤ 10KΩ 10Ω max.
額定功率 (Rated Power)	0.05W
最高使用電壓 (Max.Operating Voltage)	50V AC/20V DC
動雜音 (Rotational Noise)	Less Than 100mV
絕緣阻抗 (Insulation Resistance)	More than 100MΩ at DC 500V
耐電壓 (Withstand Voltage)	For 1minute or more at 500V AC
相互偏差 (Gang Error)	-40~0 dB ≤ 3dB(雙聯)

機械的性能:Mechanical Characteristics

全回轉角度 (Rotation Angle)	300°±5°	
旋轉力矩 (Rotation Torque)	2~20mN.m(20~200gf.cm)	
軸的拉、押強度 (Pull-Push Strength)	80N(8kgf)	
轉動止檔強度 (Rotational Stop-End Torque)	無軸套(Without bushing)	0.5 N.m(5kgf.cm)
	有軸套(With bushing)	0.6N.m(6kgf.cm)
軸的搖動量 (Shaft Wobble)	0.7*L/30mmp-p MAX.	

耐久的性能 (Durability)

回轉壽命 (Rotational Life)	10,000 cycles
------------------------	---------------