

# 外形图 Mechanical Dimensions

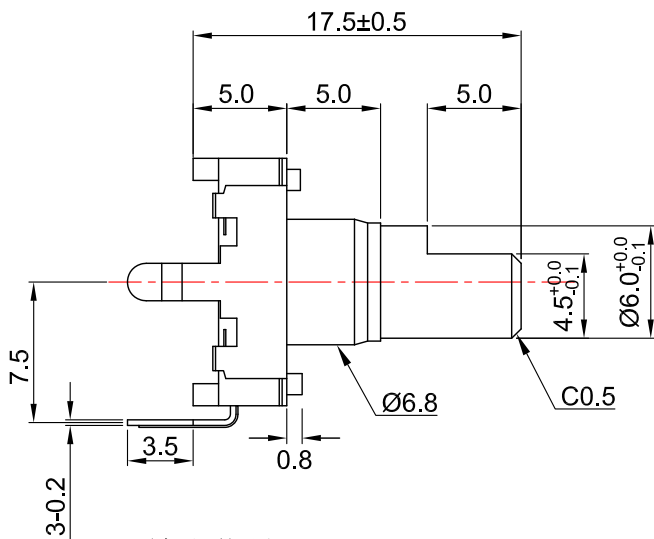

输出信号  
Output signal format

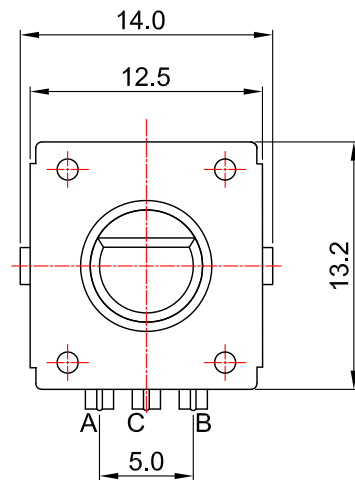

接线图  
Circuit explanation

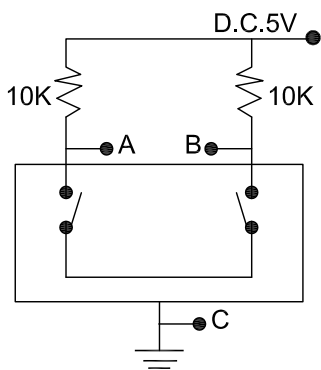
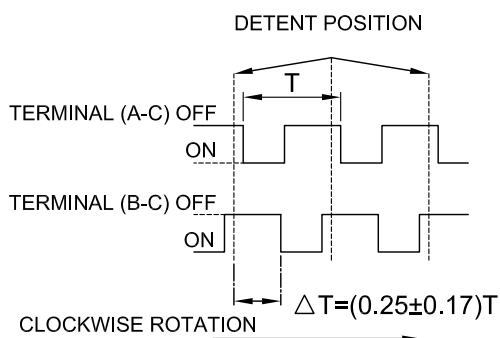

安装孔位图  
P.C.B. mounting hole detail

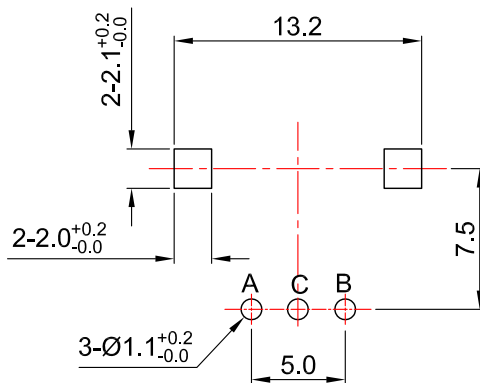

● Detent & Pulse type

Y	Detent	PULSE	
24C24P	24	24	<input type="checkbox"/>
24C12P	24	12	<input type="checkbox"/>
24P	/	24	<input type="checkbox"/>
12P	/	12	<input type="checkbox"/>
12C12P	12	12	<input type="checkbox"/>

<div style="display: flex; justify-content: space-between;"> <span>3</span> <span>2</span> <span>1</span> </div>				PRODUCT NAME	Encoder		
NO				MODEL NAME	R121EC-17.5F5D1-C-P-V01		
DATE				APPROVED BY	CHECKED BY	DRAWN BY	
DESCRIPTION				<div style="border: 1px solid black; border-radius: 50%; padding: 5px; width: 60px; margin: 0 auto;"> <b>R &amp; D</b>                      2015/4/15                      Eva                 </div>	<div style="border: 1px solid black; border-radius: 50%; padding: 5px; width: 60px; margin: 0 auto;"> <b>R &amp; D</b>                      2015/4/15                      Sophie                 </div>	<div style="border: 1px solid black; border-radius: 50%; padding: 5px; width: 60px; margin: 0 auto;"> <b>R &amp; D</b>                      2015/4/15                      Dick                 </div>	
DIMENSION	TOLERANCE	SCALE	UNIT				mm
$\int \leq 10$	$\pm 0.2$	UNIT	mm				
$10 < \int \leq 30$	$\pm 0.5$	VER.	A0				
$30 < \int \leq 100$	$\pm 1.0$	DATE	2015/4/15				
All Angles	$\pm 5^\circ$						

# R12EC SERIES SPECIFICATION R12EC系列规格书

## 1. 一般事项 General

### 1-1. 适用规格 Scope

本规格适用于微小电流回路的电子设备,属11型回转编码器.

This specification applies to 11 mm size low-profile rotary encoder (incremental type) for microscopic current circuits, used in electronic equipment.

### 1-2. 标准状态 Standard atmospheric conditions

除另有规定外,测量应在以下状态下进行:

Unless otherwise specified, the standard range of atmospheric conditions for making measurements

and test is as following limits:

温度 Ambient temperature : 15°C to 35°C

相对湿度 Relative humidity:25% to 85%

气压 Air pressure:86kpa to 106kpa

### 1-3. 使用温度范围

Operating temperature range:-10°C to 70°C

### 1-4. 保存温度范围

Storage temperature range: -40°C to+85 °C



图1

## 2. 构造 Construction

### 2-1. 尺寸 Dimensions

见所附成品图Refer to attached drawing

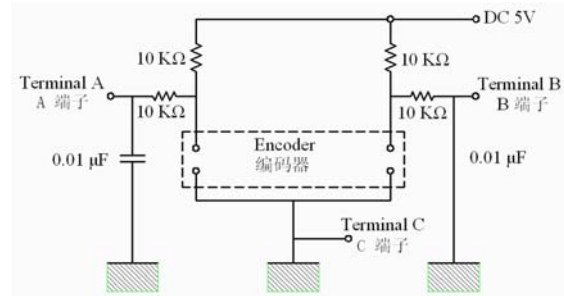
## 3. 额定值 Rating

### 3-1. 额定电压

Rated voltage :DC 5V

### 3-2. 最大额定电流(阻抗负载)

Maximum operating current (resistive load)

各相导线 Each lead : 1mA)

## 4. Application Nots 使用上的事项

4-1. 避免储藏于高温、潮湿及腐蚀的场所. 产品购入后尽可能在6个月内使用完. 拆包装后未使用完的剩余产品需储藏于防潮防毒的环境下.

Avoid storing the products in a place at high temperature, high humidity and in Corrosive gases. Please use this product as soon as possible with 6 months limitation. If any remainder left after packing is opened, please store it with proper moistureproofing, gasproofing etc.

4-2. 编码器信号的计算方法应将操作的速度,信号的取样时间及电子回路中的微电脑软件等考虑进去.

The encoder pulses count method should be designed with taking operating speed, sampling time and design of the microcomputer software into consideration.

4-3. 此产品在定位点的输出阻抗波形参照(5-1),因此在设计软体时请留意其状态.

With this products the detent position output conslnt fig.5-1. Therefore make the A phase the reference at the soft ware design stage.

4-4. 在设计时要考虑到杂讯,建议使用C/R滤波电路,(图1)

At design of the pulse count process .Using the C/R filter circuit is Recommended(fig.1)

4-5. 本产品请勿碰触到水,可能会导致输出波形的异常.

Care must be taken not to expose this product to water or dew to prevent possible problem in pluses output waveform

# R12EC SERIES SPECIFICATION R12EC系列规格书

5.电气性能 ELECTRICAL CHARACTERISTICS			
项目 ITEM	条件 CONDITIONS		规格 SPECIFICATIONS
5-1.输出信号 Output signal format	A、B两信号输出相位差，输出波形详细见（图2/3）（虚线表示带卡点装置的上擎子处位置） 2 phase different signals (signal A, signal B) Details shown in <fig.2/3> (the broken line shows detent position.)		
	轴回转方向 Shaft rotational direction	信号 Signal	输出波形 Output  图 2 fig. 2                      图 3 fig. 3
	顺时针方向 C.W	(A-C端子间) A(Terminal A-C) B (B-C端子间) B(Terminal B-C)	
	逆时针方向 C.C.W	A (A-C端子间) A(Terminal A-C) B (B-C端子间) B(Terminal B-C)	
5-2. 分解能力 Resolution	回转360°的输出脉冲数. Number of pulses in 360° rotation.		<input type="checkbox"/> 14个脉冲/360° (图2) 14Pulsrs/360° (fig2) for each phase <input checked="" type="checkbox"/> 26个脉冲/360° (图3) 24Pulsrs/360° (fig3) for each phase
5-3.开关特性 Switching characteristics	下(图4)所示回路,轴以360° /sec 的速度转动测定。 Measurement shall be made under the condition as follows . Shaft rotational speed : 360° /S    Test circuit : (fig .4) <div style="display: flex; justify-content: space-around; align-items: flex-start;"> <div style="text-align: center;"> <p>图4&lt;fig .4&gt;</p> </div> <div style="text-align: center;"> <p>图5&lt;fig .5&gt;</p> </div> </div> <p>(注) 编码 OFF 指输出电压3.5V以上的状态(fig.5). Code-OFF area :The area which the voltage is 3.5V or more(fig.5)            编码 ON 指输出电压1.5V以下的状态(fig.5). Code ON area :The area which the voltage is 3.5V or more(fig.5) .</p>		
5-3-1.振荡 Chattering	编码从OFF→ON或ON→OFF时,输出1.5V~3.5V的通过时间应符合规定。 Specified by the signal 's passage time from 1.5V to 3.5V of each switching position (code OFF~ON or ON ~OFF)		$t_1, t_3 \leq 5ms$
5-3-2.滑动杂音 (突跳) Sliding noise (Bounce)	编码 ON 部份的1.5V以上的电压变动时间在振荡t1,t3之间会产生1ms以上,1.5V以下的 ON 部份.另外,如果各突跳间1.5V以下的范围在1ms以上时,则判定为另一个突跳. Specified by the time of voltage change exceed 1.5V in code-ON area.when the bounce has code -ON time less than 1ms between chattering (t1 or t3),the voltage change shall be regarded as a part of chattering.when the code-ON time between 2 bounces is less than 1ms .they are regarded as 1 linked bounce		$t_2 \leq 5ms$
5-3-3.滑动噪音 Sliding noise	编码OFF部份的电压变动。 The voltage change in code-OFF area.		3.5 V 以上 3.5 V min

# R12EC SERIES SPECIFICATION R12EC系列规格书

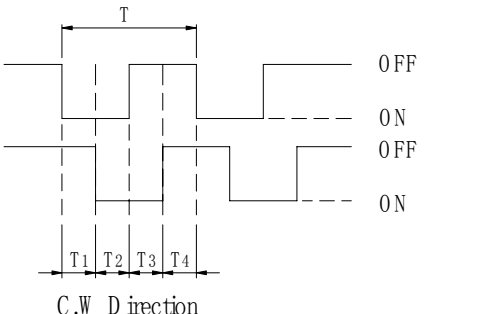
5. 电气性能 ELECTRICAL CHARACTERISTICS		
项目 ITEM	条件 CONDITIONS	规格 SPECIFICATIONS
5-4. 相差 Phase difference	<p>下(图6)所示回路, 轴以360° /S的速度转动测定。 Measurement shall be made under the condition which the shaft is rotated at 60r /min 图6 fig.6</p> <p>A信号(A~C)间 signal A</p> <p>B信号(B~C)间 signal B</p> <div style="text-align: center;">  </div>	<p>T1、T2、T3、T4 ≥ 4mS 见图6 (fig. 6)</p>
5-5. 绝缘阻抗 Insulation resistance	<p>在端子和轴间施加电压 250V DC。 Measurement shall be made under the condition which a voltage of 250V DC is applied between individual terminals and bushing .</p>	<p>100Ω 以上 100Ω Min</p>
5-6. 耐电压 Dielectric strength	<p>在端子和轴间施加 AC 300 V电压1分钟。 A voltage of 300V AC shall be applied for 1 minute between individual terminals and bushing.</p>	<p>不得有绝缘破坏 Without arcing or breakdown</p>
5-7. 端子间接触阻抗 Contact resistance	<p>出力信号处于 ON 时安定状态条件下测定。 Measurement shall be stable condition which a output signal is ON.</p>	<p>1Ω 以下 1Ω Max</p>
6. 机械性能 Mechanical characteristics		
6-1. 全回转角度 Total rotational angle		<p>360° (无止档点) 360° (End less)</p>
6-2. 定位点力矩 Detent torque	<p>只适用于附卡点装置 Only suitable for C.C, equipment.</p>	<p>3~20mN.m(30~200gf.cm) Shaft rotatable at -10°C~+5°C 但在-10°C~+5°C轴勉强可转动</p>
6-3. 定位点数及位置 Number of detent and position	<p>只适用于附卡点装置 Only suitable for C.C, equipment.</p>	<p>12detents (Step angle :12° ±2° ) 12点定位(间隔角度12° ±2° ) <input checked="" type="checkbox"/> 24detents(Step angle :18° ±2° ) <input type="checkbox"/> 24点定位(间隔角度18° ±2° )</p>
6-4. 轴的推拉强度 Push -pull strength of shaft	<p>在轴端,沿轴向施加 10Kg 的静负荷力推和拉各10秒钟 (产品焊锡固定在PCB上。) Push and pull static load of 10kg shall be applied to be shaft in the axial direction for 10s. (After soldering of the PC board)</p>	<p>轴无破损,回转无异常,电气性能无异常。 Without damage or excessive play in shaft.NO excessive abnormality in rotational feeling .And.electrical characteristics and be satisfied.</p>
6-5. 轴摆动 Shaft wobble	<p>在轴前端5mm处,沿径向瞬间施加 50mN.m (500gf.cm)的力。 A momentary load of 50mN.m (500gf.cm) shall be applied at the point 5mm from the tip of the shaft in a direction perpendicular to the axis of shaft.</p>	<p>0.8xL/30mm p-p以下(L:指安装平面到轴的柄端的距离) 0.8x1/30mm p-p Max或(l:Distance between mounting surface and measuring point on the shaft)</p>
6-6. 轴的回转方向 摆动 Shaft play in rotational wobble	<p>用角度板测定。 Testing by angle board.</p>	<p>5° 以下 5° MAX</p>

## R12EC SERIES SPECIFICATION R12EC系列规格书

7. 耐久性能 ENDURANCE CHARACTERISTICS		
项目 ITEM	条件 CONDITIONS	规格 SPECIFICATIONS
7-1. 回转寿命 Rotational life	<p>在无负荷条件下轴以 600周/小时速度回转30,000周。</p> <p>The shaft of encoder shall be rotated to 30,000 cycles at a speed of 600cycles/H without electrical load ,after with measurements shall be made.</p>	<p>端子间接触阻抗200Ω 以下。</p> <p>Contact resistance 200 Ω Max</p> <p>尚余有轻微定位感</p> <p>Vibration t1, t3≤5mS 振荡t1, t3 ≤5mS Bounce t2≤5mS 突跳 t2≤5mS Detent feeling has to remains</p>
7-2. 耐湿性 Damp heat	<p>温度40±2℃,湿度90~95%的恒温恒湿湿槽中放置48 小时后,在常温、常湿中放置1.5小时后测试。</p> <p>The encoder shall be stored at temperature of 40±2℃ with relative humidity of 90% to 95% for 48H in a thermostatic chamber.And the encoder shall be subjected to standard atmospheric conditions for 1.5H,After which measurements shall be made.</p>	<p>所有项应满足初期规格</p> <p>Specifications in clause all items is shall be satisfied .</p>
7-3. 耐热性 Dry heat	<p>温度80±3℃的恒温箱中放置48小时,然后在常温、常湿放置1.5小时后测试。</p> <p>The encoder shall be stored at a temperature of 80±3℃ for 48H in a thermostatic chamber.And the encoder shall be subjected to standard atmospheric conditions for 1.5H, After which measurements shall be made.</p>	<p>所有项应满足初期规格</p> <p>Specifications in clause all items is shall be satisfied .</p>
7-4. 低温特性 Cold	<p>温度-25±3℃的恒温箱中放置48小时,常温、常湿放置1.5小时后测试。</p> <p>The encoder shall be stored at a temperature of -25±3℃ for 48H in a thermostatic chamber.And then the encoder shall be subjected to standard atmospheric conditions for 1.5H.After which measurements shall be made.</p>	<p>所有项应满足初期规格</p> <p>Specications in clause all items is shall be satisfied .</p>
7-5. 焊锡性 Solder ability	<p>端子在260℃±5℃温度的焊锡槽内浸锡3秒±0.5秒。</p> <p>The terminals shall be immersed into solder bath at 260℃ for 3s±0.5s in the same manner as para.</p>	<p>浸渍面须有75%以上焊锡附着</p> <p>A new uniform coating of solder shall cover 75% minimum of the surface being immersed.</p>
7-6. 耐焊接热 Resistance to Soldering heat	<p>手工焊接 Manual soldering 温度300℃以下,时间3秒以内。 Bit temperature of soldering iron:300℃ less than application time of soldering iron :within 3s.</p> <p>槽焊 Dip soldering . 使用基板: t=1.6mm的单面覆铜板。 Printed wiring board :single -stded copper clad laminate board with thickness of 1.6mm.</p> <p>预热:基板表面温度100℃以下,时间1分钟以内。 Preheating:1.Surface temperature of board :100℃ or less 2.preheating time :within 1 min</p> <p>焊接:温度260±5℃或以下,时间3秒以内。 Soldering :Solder temperature:260±5℃ or less</p> <p>Immersion time :within 3s</p>	<p>不得有绝缘体的破坏、变形、接触无异常。</p> <p>Electrical characteristics shall be satisfied No mechanical abnormality.</p>

# R12EC SERIES SPECIFICATION R12EC系列规格书

## 推动开关部分 Push Switch Portion

备注:以下规格适用于R11ECS编码带开关系列.

No: The following specification is only suitable for the one type with switch construction of R11EC encoder series.

### 1. 额定值 Rating

1-1. 额定电压

Rated voltage :DC 5V

1-2. 最大额定电流(阻抗负载)

Maximum operating current (resistive load ):10mA MAX

### 2. 电气性能 ELECTRICAL CHARACTERISTICS

项目 ITEM	条件 CONDITIONS	规格 SPECIFICATIONS
2-1. 接触电阻 Contact resistance	用 DC 5V 1mA 电压测定. Voltage test at DC 5V 1mA.	100mΩ less ≤ 100mΩ
2-2. 绝缘阻抗 Insulation resistance	在端子和安装板间施加电压250V DC. Measurement shall be made under the condition which a voltage of 250V DC is applied between individual terminals and bushing and bushing and plank	100MΩ 以上 100MΩ Min
2-3. 振荡 Bouncing	以1秒钟1往返(OFF-ON-OFF)按压动作. Shaft shall be push at 1 cycles/s (OFF-ON-OFF)	10ms or less ≤ 10ms
2-4. 耐电压 Dielectric strength	在端子和安装板间施加AC300V电压1分钟 A voltage of 300V Ac shall be applied for 1 minute between individual terminals and bushing and plank.	不得有绝缘破坏 Without arcing or breakdown

### 3 机械性能 Mechanical characteristics

3-1. 开关电路.接点数 Switch circuit and number of pulse		单极单投(按压ON) Single pole and single throw (ON switch function )
3-2. 开关动作力 Operation fore of switch	在轴端,沿轴向施加的按压力. Push static load to the shaft in the axial direction.	Nil
3-3. 开关动移动量 Travel of switch		Nil

### 4 耐久性能 Endurance Characteristics

回转寿命 Rotaional life	The shaft of encoder shall be push to 20,000 cycles at a speed of 600 cycles/H without electrical load ,after with measurements shall be made.	接触电阻:≤200mΩ . 其它应满足初期规格. Contact resistance : 200mΩ or less Specifi cation in clause shall be satisfied.
------------------------	--	---

制定日期	2007-5-15	DSG.承办	CHKD.审核	APPD.批准	TITLE 标题: ENCODER 编码器 DOCUMENT No.文号: R12ECS
版本号: 00	变更记录	R & D 2009.06.04 Sam	R & D 2009.06.04 Sophie	R & D 2009.06.04 Jennifer	