

外形图 Mechanical Dimensions

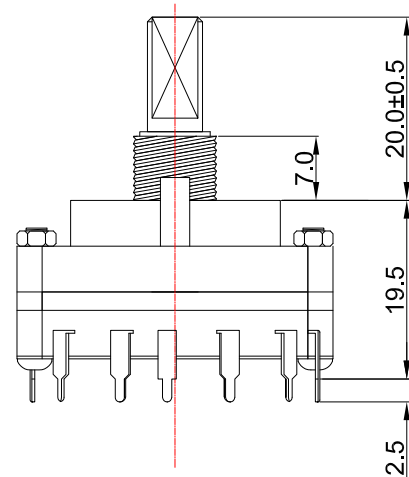

Switch pole 电性回路示意图

- | | |
|------------|--------------|
| 1段: 1个C1-1 | 7段: 1个C1-7 |
| 2段: 1个C1-2 | 8段: 1个C1-8 |
| 3段: 1个C1-3 | 9段: 1个C1-9 |
| 4段: 1个C1-4 | 10段: 1个C1-10 |
| 5段: 1个C1-5 | 11段: 1个C1-11 |
| 6段: 1个C1-6 | 12段: 1个C1-12 |

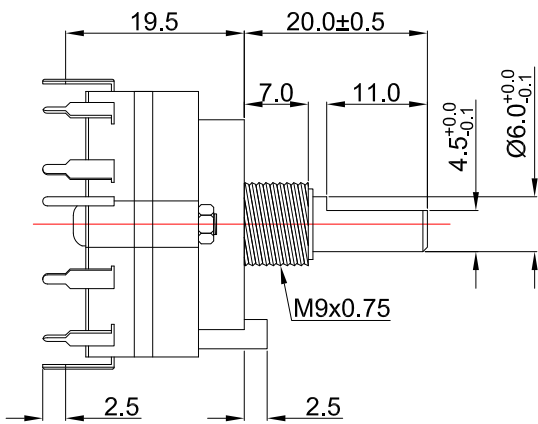
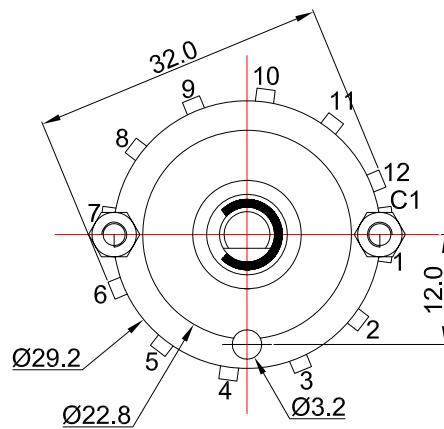

Shaft shown in full C.C.W position

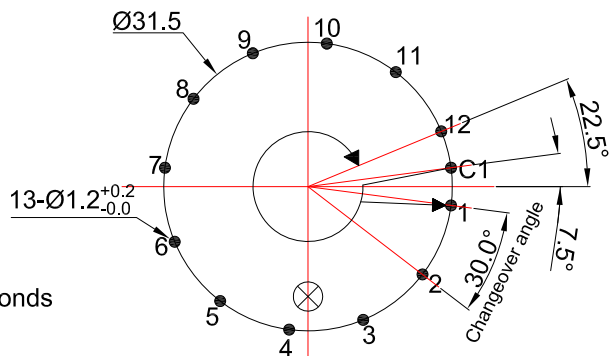

- 1.Changeover timing : **Non shorting**
- 2.Changeover angle : 30°
- 3.SWITCH RATING : DC 30V 0.5A
- 4.WITHSTAND VOLTAGE : for 1 minute at DC 500V
- 5.INSULATION RESISTANCE: DC 500V 100MΩ MIN
- 6.CONTACT RESISTANCE: 30mΩ MAX
- 6.SWITCH LIFE:10,000cycles
- 7.SOLDERING HEAT : 260 dergee and less than 5 seconds
- 9.TORQUE: 0.5~2kgf.cm

3				PRODUCT NAME	Rotary switch	
2				MODEL NAME	RS3801-20FD1-1-12P	
1				APPROVED BY	CHECKED BY	DRAWN BY
NO	DATE	DESCRIPTION				
		DIMENSION	TOLERANCE	SCALE		
		∫ ≤10	± 0.2	UNIT		mm
		10 < ∫ ≤ 30	± 0.5	VER.		A0
		30 < ∫ ≤ 100	± 1.0	DATE		2014/9/4
		All Angles	± 5°			
				<div style="border: 1px solid black; border-radius: 50%; width: 40px; height: 40px; margin: 0 auto; display: flex; flex-direction: column; justify-content: center; align-items: center;"> R & D 2014/9/4 Eva </div>	<div style="border: 1px solid black; border-radius: 50%; width: 40px; height: 40px; margin: 0 auto; display: flex; flex-direction: column; justify-content: center; align-items: center;"> R & D 2014/9/4 Sophie </div>	<div style="border: 1px solid black; border-radius: 50%; width: 40px; height: 40px; margin: 0 auto; display: flex; flex-direction: column; justify-content: center; align-items: center;"> R & D 2014/9/4 Dick </div>