

外形图 Mechanical Dimensions

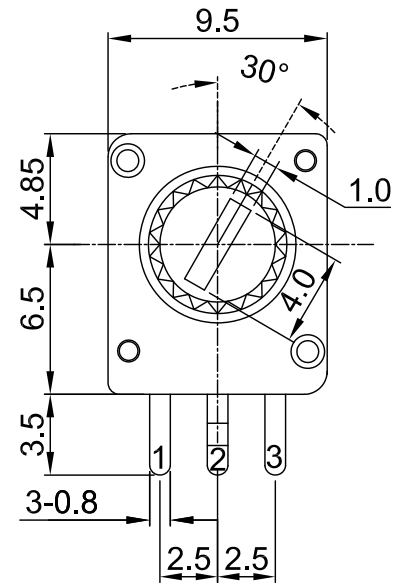

Shaft shown in full
C.C.W. position

接线图
Circuit explanation

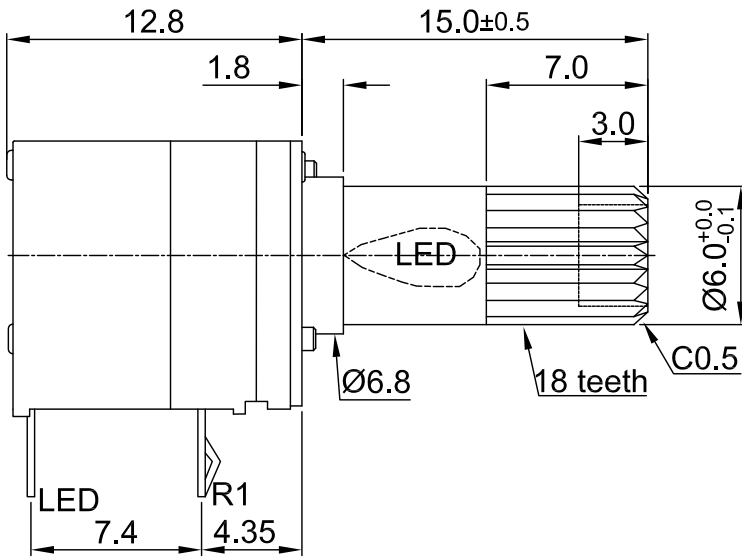
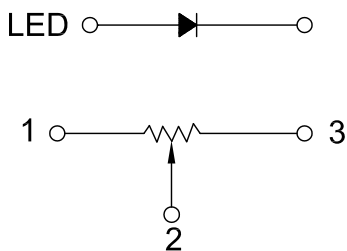

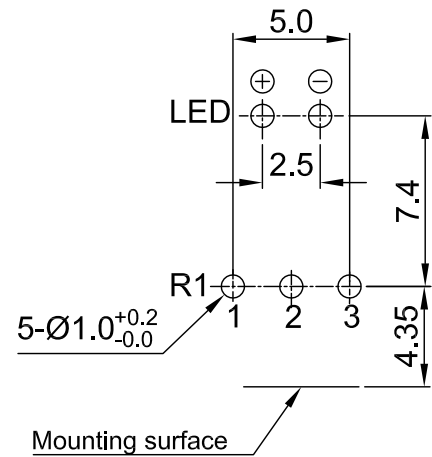

安装孔位置图
P.C.B. mounting hole detail



3				PRODUCT NAME	Rotary Potentiometer	
2				MODEL NAME	RL0911N-2A1-value	
1				APPROVED BY	CHECKED BY	DRAWN BY
NO	DATE	DESCRIPTION				
		DIMENSION	TOLERANCE	SCALE		
		$\int \leq 10$	± 0.2	UNIT	mm	
		$10 < \int \leq 30$	± 0.5	VER.	A0	
		$30 < \int \leq 100$	± 1.0	DATE	2013/05/30	
		All Angles	$\pm 5^\circ$			

9 mm Rotary Potentiometers series Specifications

1. 電氣性能 (Electrical Characteristics)					
1.1	全阻抗值 (Total Resistance)		1KΩ ~ 2MΩ		
1.2	全阻抗值允許偏差 (Total Resistance Tolerance)		±20% (More than 1 M Ω ±30%)		
1.3	電阻隨溫度變化特性 Resistance of temperature change character)		20℃-75℃:△R/R≤±5%, -25℃-20℃:△R/R≤±4.5%		
1.4	阻值變化特性 (Resistance Taper)		A, B , C, W		
1.5	零位阻值 (Residual Resistance)		R>250KΩ / 0.1 % max. of total Value 250KΩ>R>10KΩ / 20Ω max. 10KΩ>R / 10Ω max.		
1.6	額定功率 (Rated Power)		Linear Taper B: 0.05W Other Taper:0.025W		
1.7	最高使用電壓 (Max.Operating Voltage)		50V AC		
1.8	動雜音 (Rotational Noise)		Less Than 100mV		
1.9	絕緣阻抗 (Insulation Resistance)		More than 100MΩ at DC 250V		
1.10	耐電壓 (Withstand Voltage)		For 1 minute at: AC 250V		
1.11	同步誤差 (Gang Error)		-----		
2. 機械性能 (Mechanical Characteristics)					
2.1	全回轉角度 (Rotation Angle)		300°±10°		
2.2	旋轉力矩 (Rotation Torque)		10~200gf.cm		
2.3	軸的拉、押強度 (Pull-Push Strength)		2 Kgf.cm		
2.4	轉動止檔強度 (Rotational Stop-End Torque)		2 kgf.cm Min		
2.5	旋轉定位數目 (Number of Detents(click))		detent: 0, 0r 1 centre click		
2.6	焊錫耐熱性 (Resistance To Soldering Heat)		260±5℃and less than 3 seconds		
3. LED性能 (LED Characteristics)					
3.1	發光顏色(Eimitting Color)		紅色(Red), 黃色(Yellow), 藍色(Blue), 橙色(orange)		
3.2	逆向電壓(Reverse Voltage)		5V		
3.3	連續工作電流(Continuous Forward Current)(Ma)		16-18		
3.4	正向電壓(Forward Voltage)		3V		
4. 耐久性能 (Durability)					
4.1	回轉壽命 (Rotation Life)		10,000 Cycles min.		
4.2	工作溫度 (Operating temperature)		-10℃ ~ +70℃		
4.3	外形尺寸圖/曲線特性圖 (Shape size drawing/curve characteristic drawing)		見附頁 Please refer the drawing		
批 准			審 核		
			設 計		

RESISTANCE TAPER



TAPER B SERIES

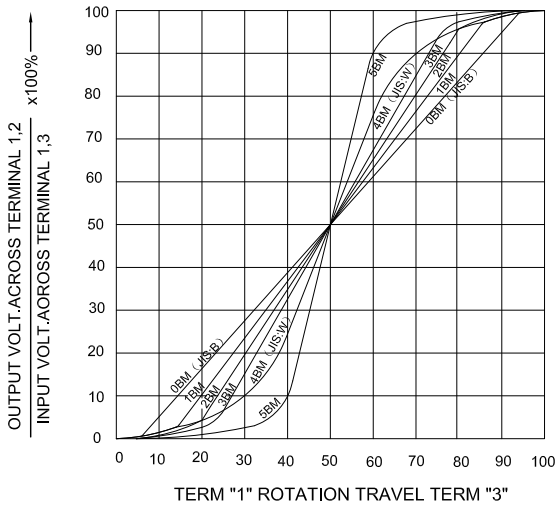

TAPER B WITH 50% TAP

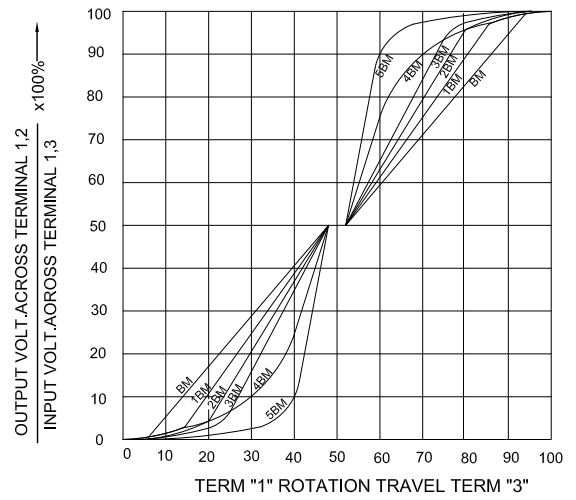

TAPER A SERIES

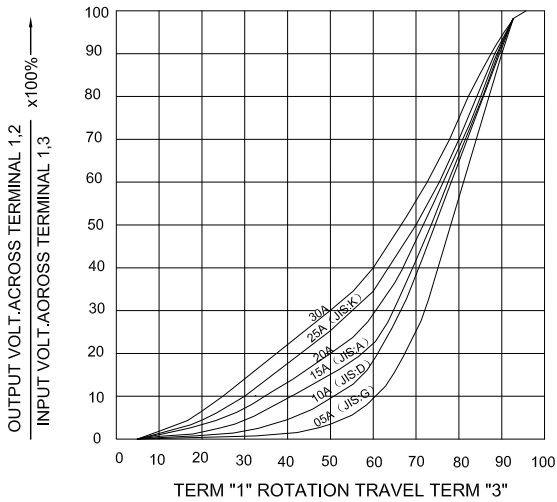

TAPER A & C WITH 50% TAP

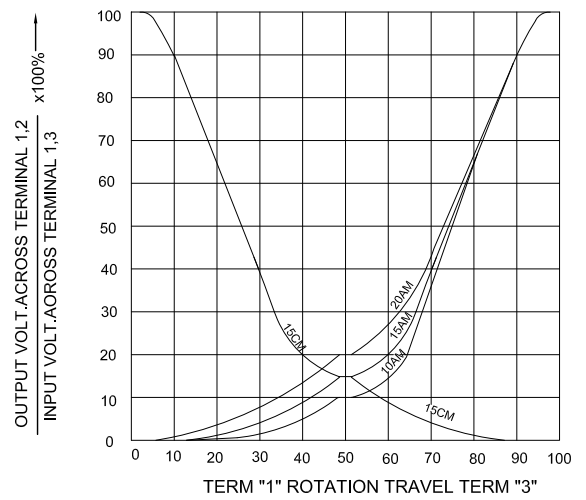

TAPER C SERIES

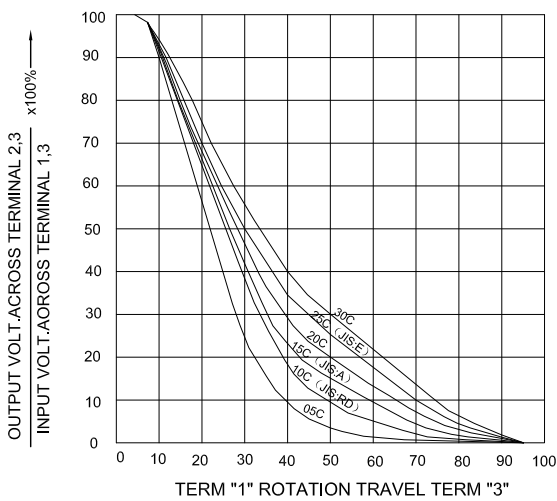

TAPER M & N SERIES

