

# 外形图 Mechanical Dimensions

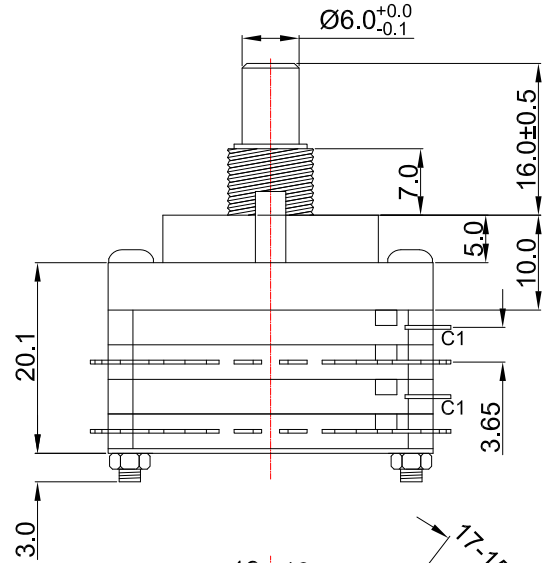

### Switch pole 电性回路示意图

- |              |              |
|--------------|--------------|
| 1段: 2个C1-1   | 13段: 2个C1-13 |
| 2段: 2个C1-2   | 14段: 2个C1-14 |
| 3段: 2个C1-3   | 15段: 2个C1-15 |
| 4段: 2个C1-4   | 16段: 2个C1-16 |
| 5段: 2个C1-5   | 17段: 2个C1-17 |
| 6段: 2个C1-6   | 18段: 2个C1-18 |
| 7段: 2个C1-7   | 19段: 2个C1-19 |
| 8段: 2个C1-8   | 20段: 2个C1-20 |
| 9段: 2个C1-9   | 21段: 2个C1-21 |
| 10段: 2个C1-10 | 22段: 2个C1-22 |
| 11段: 2个C1-11 | 23段: 2个C1-23 |
| 12段: 2个C1-12 |              |

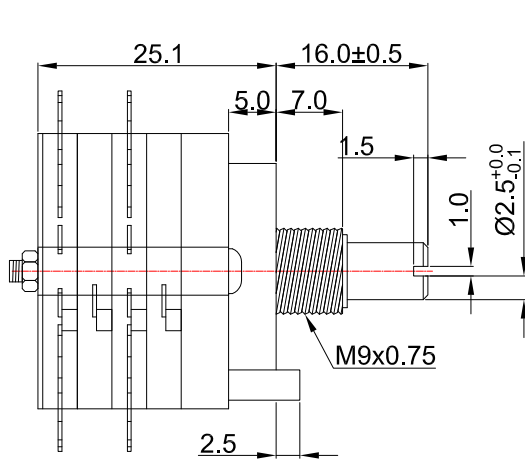
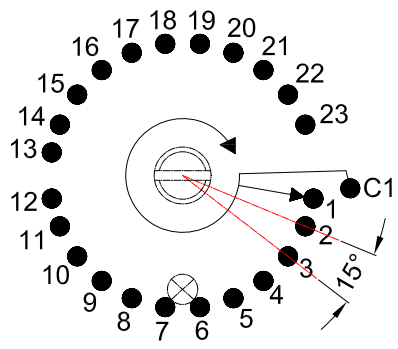
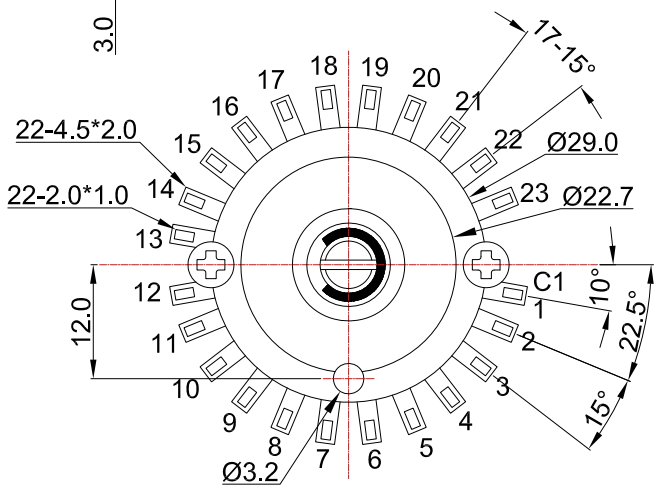

1. SWITCH RATING : DC 30V 0.5A
2. WITHSTAND VOLTAGE : for 1 minute at DC 500V
3. INSULATION RESISTANCE: DC 500V 100MΩ MIN
4. CONTACT RESISTANCE: 30mΩ MAX
5. SWITCH LIFE: 10,000 cycles
6. SOLDERING HEAT : 260 degree and less than 5 seconds
7. TORQUE: 0.5~1.5kgf.cm

3				PRODUCT NAME	Rotary switch	
2				MODEL NAME	RS3802-16SB1-1-23P	
1				APPROVED BY	CHECKED BY	DRAWN BY
NO	DATE	DESCRIPTION				
		DIMENSION	TOLERANCE	SCALE		
		$f \leq 10$	$\pm 0.2$	UNIT		
		$10 < f \leq 30$	$\pm 0.5$	VER.		
		$30 < f \leq 100$	$\pm 1.0$	DATE	2014/9/4	
		All Angles	$\pm 5^\circ$			
				