

外形圖 Mechanical Dimensions

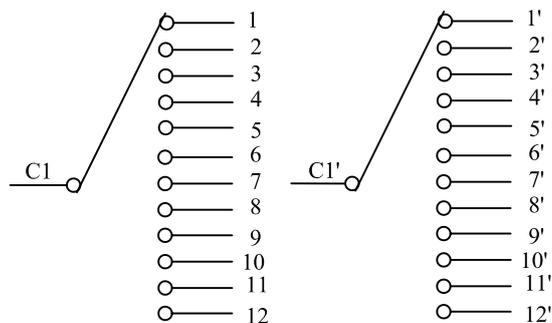
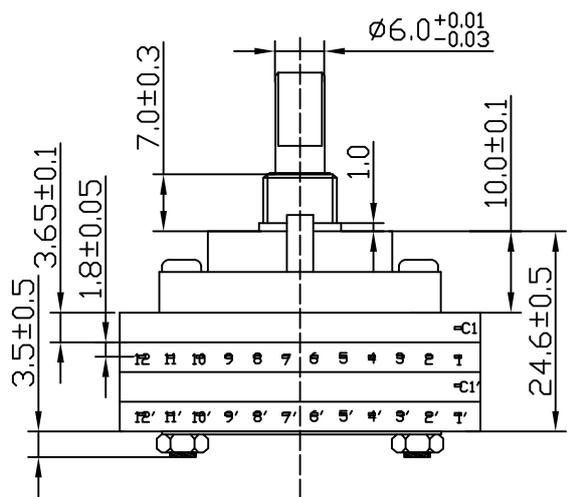
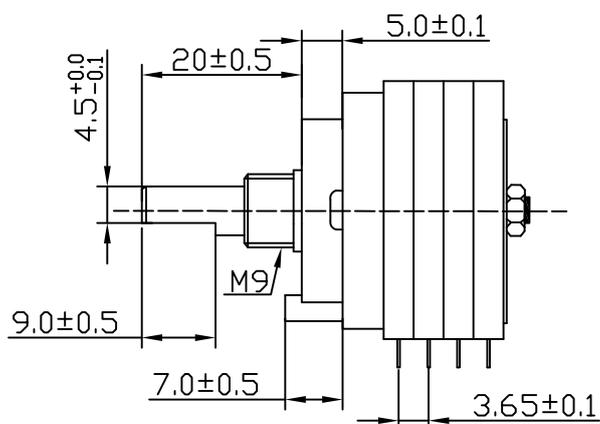
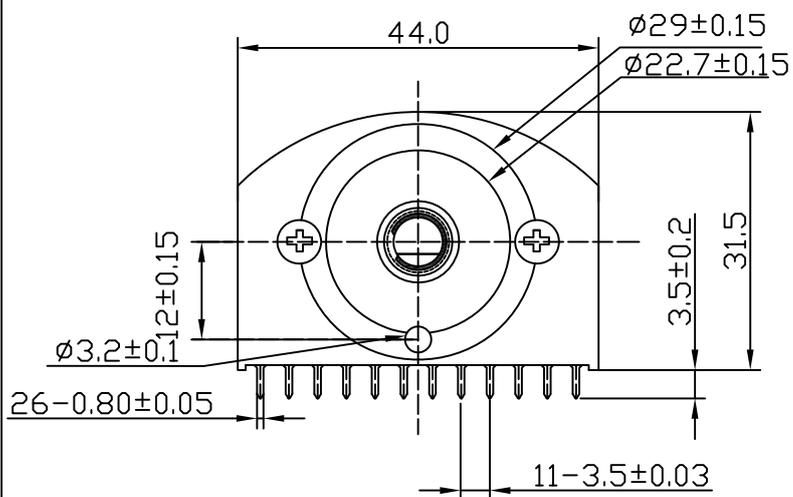

电性回路示意图

A段:	C1-1	G段:	C1-7
	C1'-1'		C1'-7'
B段:	C1-2	H段:	C1-8
	C1'-2'		C1'-8'
C段:	C1-3	I段:	C1-9
	C1'-3'		C1'-9'
D段:	C1-4	J段:	C1-10
	C1'-4'		C1'-10'
E段:	C1-5	K段:	C1-11
	C1'-5'		C1'-11'
F段:	C1-6	L段:	C1-12
	C1'-6'		C1'-12'

3			PRODUCT NAME	多路開關	
2			MODEL NAME	RS44-2-2-12-7-20F9 (400g)	
1			APPROVED BY	CHECKED BY	DRAWN BY
NO	DATE	DESCRIPTION			
DIMENSION	TOLERANCE	SCALE			
$l \leq 10$	± 0.2	UNIT	mm		
$10 < l \leq 30$	± 0.5	VER.			
$30 < l \leq 100$	± 1.0	DATE	07/08/10		